

LMX-2012G-SFP Series

20-Port Industrial Gigabit Light Layer 3 Managed Ethernet Switch, with 8*10/100/1000Tx and 12*100/1000 SFP Slots



Features

- ▶ Supports 8*10/100/1000Tx Gigabit Ethernet and 12*100/1000 SFP Slots
- ▶ Network Redundancy Support: STP/RSTP/MSTP, and G.8032 ERPS (Recovery Time <50ms)
- ▶ Supports IPv4/IPv6, and DHCP Option 66/67/82
- ▶ Supports Modbus/TCP Protocol for Device Management and Monitoring
- ▶ IGMP v1/v2/v3 for Multicast Traffic Filtering
- ▶ QoS (IEEE 802.1p/1Q), CoS/ToS to Increase Determinism
- ▶ IEEE802.1Q VLAN for Easy Network Planning
- ▶ Enhanced Network Security with IEEE802.1X, SNMP v1/v2c/v3, HTTPS, and SSH/SSL
- ▶ Auto Warning by Exception through Relay Output
- ▶ Operating Temperature Range
 - STD: -10°C to 65°C, EOT: -40°C to 75°C
- ▶ 5-Year Warranty

INTRODUCTION

Antaira Technologies' LMX-2012G-SFP series is a 20-port industrial Gigabit managed Ethernet switch that is embedded with 8*10/100/1000Tx Ethernet ports and 12*100/1000 SFP slots. The LMX-2012G-SFP series is a fully manageable light layer 3 Ethernet switch that is pre-loaded with a user-friendly web management console design. It supports the ring network redundancy function using the market's open standard ITU-T G.8032 ERPS (Ethernet Ring Protection Switch) protocol that has a <50ms network recovery time. The advanced network filtering and security functions, such as, IGMP, VLAN, QoS, SNMP, port lock, RMON, Modbus TCP, and 802.1X/HTTPS/SSH/SSL increase determinism and improve network management for remote SCADA systems or control networks.

The LMX-2012G-SFP series is IP30 rated and DIN-rail mountable. There are also two wide-operating temperature models for either a standard temperature range (STD: -10°C to 65°C) or an extended temperature range (EOT: -40°C to 75°C). It also provides high EFT and ESD protection for industrial networking applications, such as, power/utility, water wastewater, oil/gas/mining, factory automation, security surveillance within transportation, ITS and any other outdoor or harsh environment.

DIMENSIONS

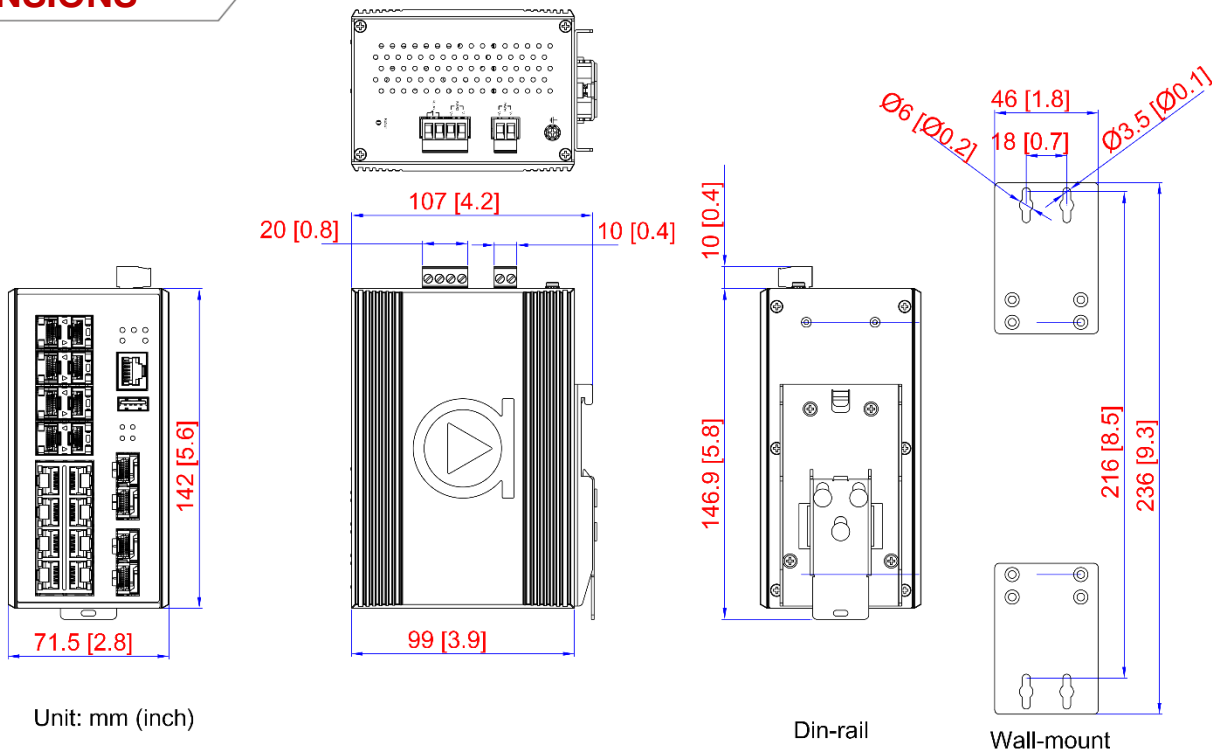

SPECIFICATIONS

Technology	Port/MAC/Protocol/IP Subnet-based VLAN, GARP/GVRP, Loop Guard, Link Aggregation static/LACP, BPDU guard, Error disable recovery, IGMP snooping v2/v3, MLD snooping v1/v2, IGMP filtering, IPMC throttling / filtering leave proxy, DHCP snooping, G.8032 v1/v2
L2 Switching	DHCP option82, static routes
L3 Switching	802.1p Queueing, Input priority mapping, Storm control for Unicast/Multicast/Broadcast, Port/Queue/ACL policer, Port egress shaper, Queue egress shaper, DiffServ (DSCP), Tag remarking, Scheduler mode
QoS	ActiPHY, PerfectReach, IEEE 802.3az EEE power management
Power Saving	STP/RSTP/MSTP, port trunk with LACP, ERPS v1/v2 (<50ms)
Network Redundancy	Http, Https, Telnet, SSH, CLI, TFTP, SNMP v3
Configuration	Dual Image Protection, PING, PING6
System / Diagnostics	
Switch Properties	
Switch Architecture	Back-Plane (Switching Fabric): 40.0Gbps IPv4/IPv6, SNMP v1/v2c/v3, LLDP, LLDP-MED, HTTP, HTTPS, SSHv2 telnet, DHCP client, DHCPv6 client, DHCP server, Port Mirror, DNS client/proxy, IP based Access Filter, ICMPv6, syslog, Time Zone / Daylight Saving, NTP client, RMON, sFlow, Loop detection, Console Port, Power Lost Warning, Relay Trigger
Protocols	8
Priority Queues	Store and Forward
Processing Type	IEEE 802.3x for full duplex mode, back pressure for half duplex mode
Flow Control	14,880pps for Ethernet Port 148,800pps for Fast Ethernet Port 1,488,000pps for Gigabit Ethernet Port
Transfer Rate	4Mbits
Memory Buffer	9.6Kbytes
Jumbo Frame	8K
MAC Table Size	4095
VLAN Group	1024
IGMP Group	
Port Interface	
Ethernet Port	8*10/100/1000BaseTx Auto negotiation speed, Full/Half duplex mode, and auto MDI/MDI-X connection
SFP Port	12*100/1000 SFP Slots
RS232 Serial Console	1*RS232 in RJ45 connector with console cable, 115.2Kbps, 8, N, 1
Configuration Backup	1*USB 2.0
LED Indicators	System: Power 1, Power 2, Status, Master, Ring Ethernet: Speed/Link/Active SFP: Link/Active

Protection	10Base-T: 2-pair UTP/STP Cat. 3, 4, 5 cable EIA/TIA-568 100-ohm (100m)
Network Cable	100Base-TX: 2-pair UTP/STP Cat. 5 cable EIA/TIA-568 100-ohm (100m) 1000Base-TX: 4-pair UTP/STP Cat.5/5E cable; EIA/TIA-568 100-ohm (100m)
Mechanical Characteristics	
Housing	Metal, IP30 rated
Dimensions	71.5 x 142 x 99 mm (W x H x D)
Weight	Unit: 3.4 lbs Shipping: 4.18 lbs
Mounting	DIN-Rail mounting, Wall mounting
Power Requirement	
Input Voltage	12~48VDC Redundant Input
Power Connection	1 removable 4-contact terminal block and 1 removable 2-contact terminal block
Relay Contact	24VDC, 1A resistive
Overload Current Protection	Present (Slow-Blown Fuse)
Reverse Polarity Protection	Present
System Power Consumption	19W
Environmental Limits	
Operating Temperature	STD: -10°C to 65°C EOT: -40°C to 75°C
Storage Temperature	-40°C to 85°C
Ambient Relative Humidity	5% to 95%, (non-condensing)
Regulatory Approvals	
EMI	FCC Part 15 Subpart B Class A, CE EN55032/EN61000-6-4 Class A
EMS	CE EN55035/EN61000-6-2: IEC61000-4-2,3,4,5,6,8
Free Fall	IEC60068-2-32
Shock	IEC60068-2-27
Vibration	IEC60068-2-6
Green	RoHS Compliant
Certifications	FCC, CE, UL 61010-1, UL 61010-2-201, NEMA TS2
Warranty	5 Years

ORDERING INFO

LMX-2012G-SFP	20-Port Industrial Gigabit Light Layer 3 Managed Ethernet Switch, with 8*10/100/1000Tx Ports and 12*100/1000 SFP Slots
LMX-2012G-SFP-T	20-Port Industrial Gigabit Light Layer 3 Managed Ethernet Switch, with 8*10/100/1000Tx Ports and 12*100/1000 SFP Slots; EOT: -40°C to 75°C